



**Weyn-Lauwers** N.V.

Industriepark-Noord 12  
B - 9100 SINT-NIKLAAS

Tel. : 00 32 (0)3 776.34.13  
Fax : 00 32 (0)3 778.09.52  
weynlauwers@weynlauwers.be  
www.weynlauwers.be

# BALL CHECK VALVE PVC - BSP fig 745

## DESIGN FEATURES

- ball check valve 1 1/4"-3" PN10
- threaded BSP
- min. temp : 0°C
- max. temp : +60°C
- specifications : ball type  
materials : PVC-U  
removable bonnet

## USE

- water distribution and watering
- max. pressure : 10 bar

## MATERIALS

item	Part name	Material
1	body	PVC-U
2	bonnet gasket	EPDM
3	bonnet	PVC-U
4	ball	PVC-U
5	ring	PVC-U
6	gasket	EPDM
7	ends	PVC-U
8	nut	PVC-U

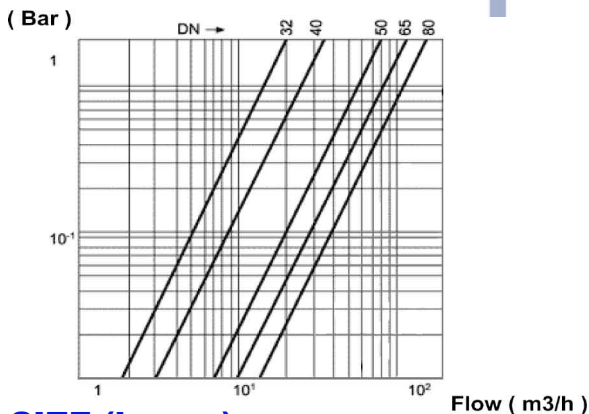
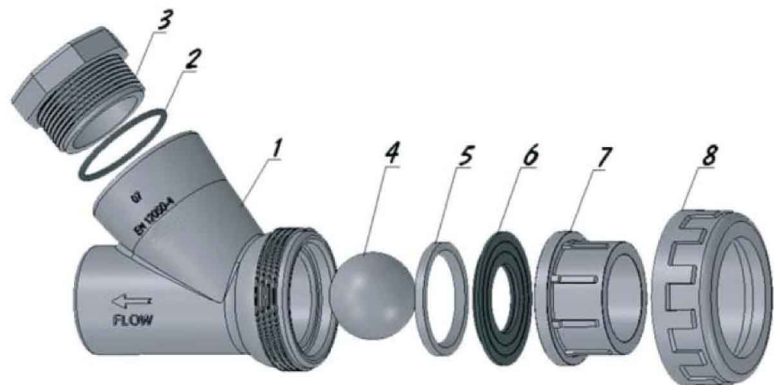
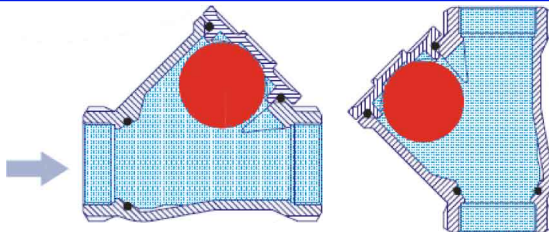

## SIZE (in mm)

DN	1 1/4"	1 1/2"	2"	2 1/2"	3"
L	144	158	190	270	324
H	127	158	181	238	286
A	81	99	112	154	178
B	61	71	90	114	137
kg	0,413	0,693	1,148	2,411	4,121
ref.	745.07	745.08	745.09	745.10	745.11

